

Refrigeration compressor ZR12M3E-TWD



Producer: **Copeland**

Line: **ZR**

Model: **ZR12M3E-TWD**

Cooling capacity [kW]: **15.20**

Heat rejection [kW]: **22.11**

Displacement [m³/h]: **28.8**

Refrigerant: **R22, R134a, R407C**

Capacity control: **None**

Power supply: **400V/3Ph/50Hz**

Data

Technical data

Displacement	[m ³ /h]	28.8
Oil charge	[l]	4.10
Oil type		POE RL32-3MAF
Internal free volume	[dm ³]	19.8
Net weight	[kg]	91.00
Gross weight	[kg]	97.00

Electrical data and limits

Power supply		400V/3Ph/50Hz
Maximum continuous current	[A]	22.0
Locked rotor amperage	[A]	127.0
Motor resistance main	[Ω]	1.02
Maximum suction pressure	[bar]	20.0
Maximum discharge pressure	[bar]	32.0
Maximum suction temperature	[°C]	52.0
Minimum suction temperature	[°C]	-35.0

Dimensions

Suction tube diameter	[inch]	1 3/8
Discharge tube diameter	[inch]	7/8
Suction connection thread diameter	[inch]	1 3/4
Discharge connection thread diameter	[inch]	1 1/4
Length	[mm]	319
Height	[mm]	525
Width	[mm]	357

Other

Approved refrigerants	R22, R134a, R407C
Allowed oil types	POE RL32-3MAF, POE MOBIL EAL Arctic 22 CC
Capacity control	None
Protection rating	IP54 (IEC34)

Performance

Nominal conditions: refrigerant: R407C, evaporation: -10°C (dew point), condensation: 45°C (dew point), superheating: 10K, subcooling: 0°C

Cooling capacity

		Evaporation temperature [°C]									
		-20	-15	-10	-5	0	5	7	10	12.5	15
Condensation temperature [°C]	10	14.55	17.99	22.07	26.88						
	15	13.86	17.20	21.17	25.83	31.26					
	20	13.16	16.40	20.24	24.74	29.99	36.07				
	25	12.45	15.59	19.28	23.62	28.69	34.55	37.14	41.29		
	30	11.73	14.75	18.30	22.48	27.34	32.98	35.47	39.47	43.06	46.89
	35	10.99	13.89	17.30	21.30	25.96	31.38	33.77	37.61	41.06	44.74
	40	10.23	13.00	16.26	20.08	24.54	29.72	32.01	35.69	39.00	42.54
	45		12.10	15.20	18.83	23.08	28.02	30.20	33.72	36.89	40.28
	50			14.10	17.54	21.57	26.27	28.35	31.70	34.72	37.95
	55				16.22	20.02	24.46	26.44	29.62	32.49	35.57
	60					18.43	22.61	24.47	27.48	30.20	33.12
	65						20.71	22.45	25.29	27.85	30.61
68							19.54	21.22	23.94	26.41	29.07

Heat rejection

		Evaporation temperature [°C]									
		-20	-15	-10	-5	0	5	7	10	12.5	15
Condensation temperature [°C]	10	17.79	21.18	25.27	30.17						
	15	17.50	20.78	24.71	29.39	34.93					
	20	17.23	20.41	24.19	28.67	33.95	40.16				
	25	16.98	20.07	23.71	28.00	33.05	38.96	41.60	45.86		
	30	16.74	19.76	23.27	27.38	32.21	37.85	40.35	44.41	48.07	52.01
	35	16.50	19.46	22.86	26.81	31.42	36.80	39.19	43.05	46.54	50.28
	40	16.27	19.17	22.48	26.28	30.69	35.81	38.09	41.76	45.08	48.65
	45		18.90	22.11	25.78	30.00	34.89	37.06	40.55	43.71	47.10
	50			21.77	25.31	29.36	34.02	36.08	39.41	42.41	45.63
	55				24.87	28.75	33.20	35.17	38.33	41.18	44.23
	60					28.18	32.43	34.30	37.31	40.01	42.91
	65						31.70	33.48	36.34	38.91	41.66
68							31.28	33.01	35.79	38.27	40.94

Power consumption

		Evaporation temperature [°C]											
		-20	-15	-10	-5	0	5	7	10	12.5	15		
Condensation temperature [°C]	10	3.41	3.37	3.37	3.45								
	15	3.83	3.77	3.73	3.75	3.86							
	20	4.28	4.22	4.16	4.13	4.17	4.30						
	25	4.76	4.72	4.66	4.61	4.59	4.65	4.70	4.81				
	30	5.27	5.27	5.23	5.17	5.12	5.12	5.14	5.20	5.28	5.39		
	35	5.80	5.87	5.86	5.81	5.75	5.71	5.71	5.73	5.76	5.83		
	40	6.35	6.50	6.54	6.52	6.47	6.41	6.40	6.39	6.40	6.43		
	45		7.16	7.28	7.31	7.29	7.23	7.21	7.19	7.18	7.18		
	50			8.08	8.18	8.20	8.16	8.15	8.11	8.09	8.08		
	55				9.11	9.19	9.20	9.19	9.17	9.14	9.12		
	60					10.27	10.34	10.35	10.34	10.33	10.31		
	65						11.58	11.61	11.64	11.64	11.63		
	68							12.37	12.42	12.47	12.49	12.49	

Application range

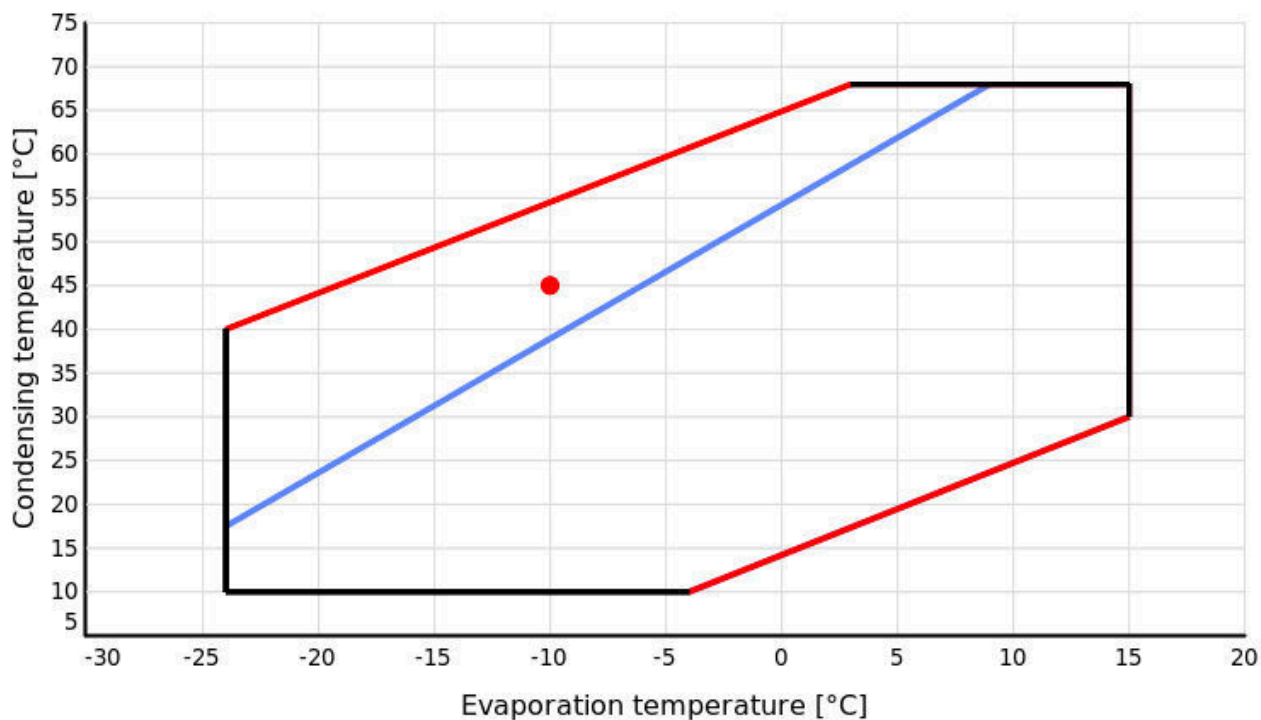

Legend

- Suction gas superheating: 10 K
- Suction gas temperature: 25°C

Dimensions

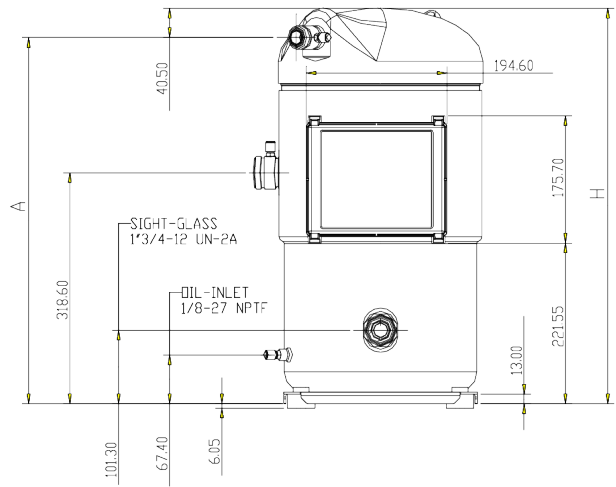
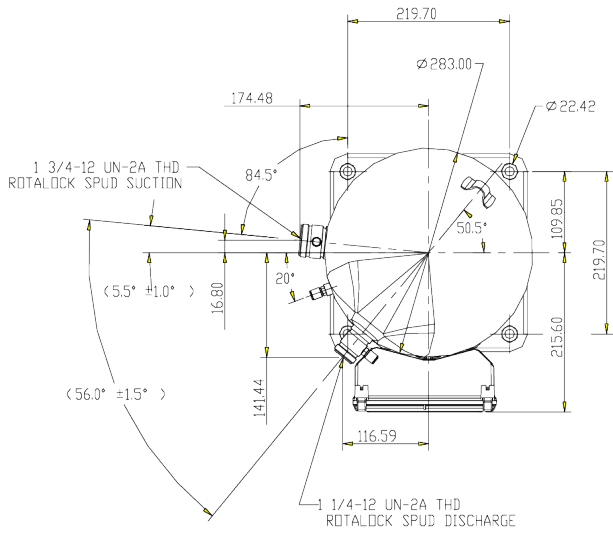

Dimensions

Dimension A [mm] 497,34

Tube diameters

Dimension H 537,84